



**MACHINE SERVICE, INC.**  
**A WORLD ABOVE THE COMPETITION**



**COMPACT & SPLIT YOKE DESIGNS**

**Universal Joint Couplings  
for Industrial Applications**



**MACHINE SERVICE, INC**



**MSI MACHINE SERVICE, INC**

PO Box 10265  
Green Bay, WI 54307-0265

Shipping Address:  
1000 Ashwaubenon Street  
Green Bay, WI 54304

Telephone: **800-677-8711**  
920-339-3000  
Telefax: 920-339-3003



## **TABLE OF CONTENTS:**

<u>Preface</u>	<u>Page 2</u>
<u>Series 615 through 640; High Bearing Life Design; 2400 Nm up to 14000 Nm</u>	<u>Page 3</u>
<u>Series 645 through 560; High Bearing Life Design; 17000 Nm up to 57000 Nm</u>	<u>Page 5</u>
<u>Series 360 through 380; High Bearing Life Design; 60000 Nm up to 255000 Nm</u>	<u>Page 7</u>
<u>Series 250 through 290; High Torque Design; 70000 Nm up to 1150000 Nm</u>	<u>Page 9</u>
<u>Companion Flanges</u>	<u>Page 11</u>
<u>Important Formulas and Conversion Factors</u>	<u>Page 13</u>
<u>Application Data Questionnaire</u>	<u>Page 14</u>

## **Preface:**

Machine Service, Inc. is a market leader in the engineering, manufacturing and distribution of Universal Driveshafts. Our 50 plus years of experience will help solve your toughest applications. The following listings of standard sizes and designs are to be used as reference only. Verify all selections with MSI Application Engineering (see application data sheet, page 14).

Other designs (e.g. special flanges, long slips, short versions, quick disconnects, torque limiters etc.) and custom machining are available at short lead-times.

For installation and maintenance questions, please see our "Installation and Maintenance Guide".



**TS**

with length compensation, tubular design

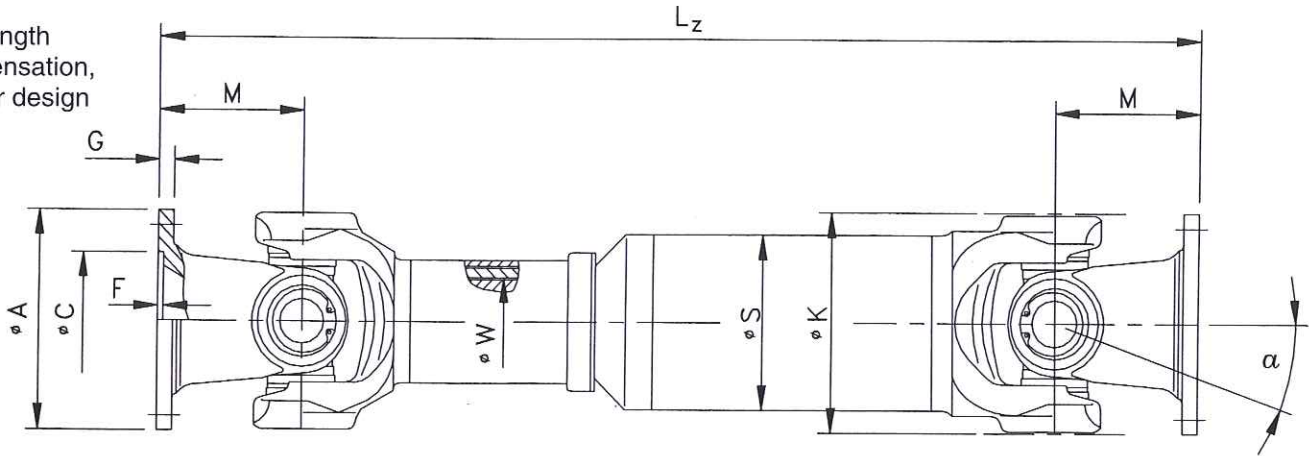

**T**

without length compensation, tubular design

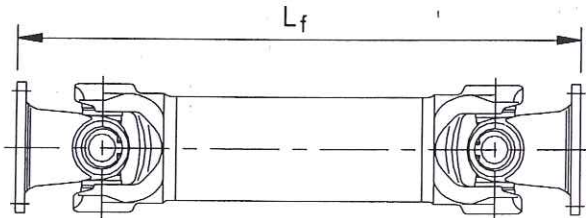

**SC1 SC2  
SC3 SC4**

with length compensation, short design

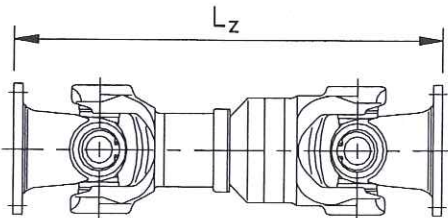

**FF**

without length compensation, double flange shaft design

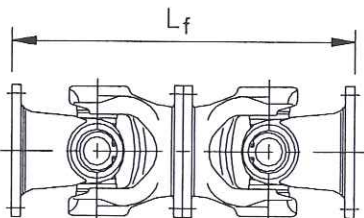



<b>MSI SERIES</b>	615090	615100	620120	625120	625150	630120	630150	635150	635180	640150	640180
-------------------	--------	--------	--------	--------	--------	--------	--------	--------	--------	--------	--------

### Capacity:

T <sub>FL</sub>	Nm	2400	3500	5000	6500	10000	14000
T <sub>K</sub>	Nm	1800	2700	3800	5000	7700	10500
T <sub>FT</sub>	Nm	700	1000	1600	1900	2900	4400
T <sub>C100</sub>	Nm	700	960	1400	1550	2500	3550
T <sub>C1000</sub>	Nm	350	480	700	775	1250	1775

T<sub>FL</sub>= Functional Limit Torque; T<sub>K</sub> = Catalog Torque; T<sub>FT</sub> = Fatigue Torque (reversing applications)

T<sub>C100</sub>= Continuous Torque at 100 RPM, 3 deg and 20,000 hours B-10 Bearing Life

T<sub>C1000</sub>= Continuous Torque at 1000 RPM, 3 deg and 20,000 hours B-10 Bearing Life

### Dimensions:

Flange	A	mm	90	100	120	120	150	120	150	150	180	150	180
Angle	α	Deg	35	25	25	25	25	25	25	25	25	25	25
Swing	K	mm	90		98	113		127		142		158	
BC	B	mm	74.5	84	101.5	101.5	130	101.5	130	130	155.5	130	155.5
Pilot	C	mm	47	57	75	75	90	75	90	90	110	90	110
Depth	F	mm	2.5	2.5	2.5	2.5	2.5	2.5	2.5	3	3	3	3
Thickness	G	mm	6	7	8	8	8	8	10	10	12	10	12
Boltholes	H	mm	8.25	8.25	10.25	10.25	12.1	10.25	12.1	12.1	14.1	12.1	14.1
# of bolts	I	mm	4	6	8	8	8	8	8	8	8	8	8
End to cl	M	mm	52	48	54	70	60	72	75	95	90	102	102
Tubing	S	Inch	2.000 x .095	2.500 x .095	3.000 x .095	3.500 x .095		3.500 x .134		4.000 x .156		4.750 x .188	
Spline	W	mm	36x1.5		40x1.5	45x1.5		48x1.5		54x1.5		62x1.75	

### Length Variations [mm]:

Design \ Series		615090	615100	620120	625120	625150	630120	630150	635150	635180	640150	640180
TS	Min. Length L <sub>z</sub>	354	346	379	438	418	504	514	582	572	586	586
	Slip	60	60	70	100	100	110	110	110	110	110	110
T	Fixed Length L <sub>f</sub>		221	239	262	242	322	332	379	369	423	423
SC 1	Length L <sub>z</sub>		308	381	405	360		415	550			545
	Slip		50	60	80	55		60	110			110
SC 2	Length L <sub>z</sub>		348	341					485			
	Slip		90	60					45			
SC 3	Length L <sub>z</sub>	249	265	276	325		347		424		476	441
	Slip	25	45	29	40		45		50		80	45
SC 4	Length L <sub>z</sub>						331				441	
	Slip						29				45	
FF	Length L <sub>f</sub>	204	192	216	280	240	288	300	380	360	408	408

Please verify all drive shaft selections with MSI engineering.

Flange may have to be reinforced to transmit max. torque.

**Longer Slip** and **High Angle** versions are available.

Above listed are standard metric flange patterns. **Special Flange Patterns** are available upon request.

Weights, torsional stiffness and inertia information can be supplied.

Please consult **MSI engineering**.



**TS**  
 with length  
 compensation,  
 tubular design

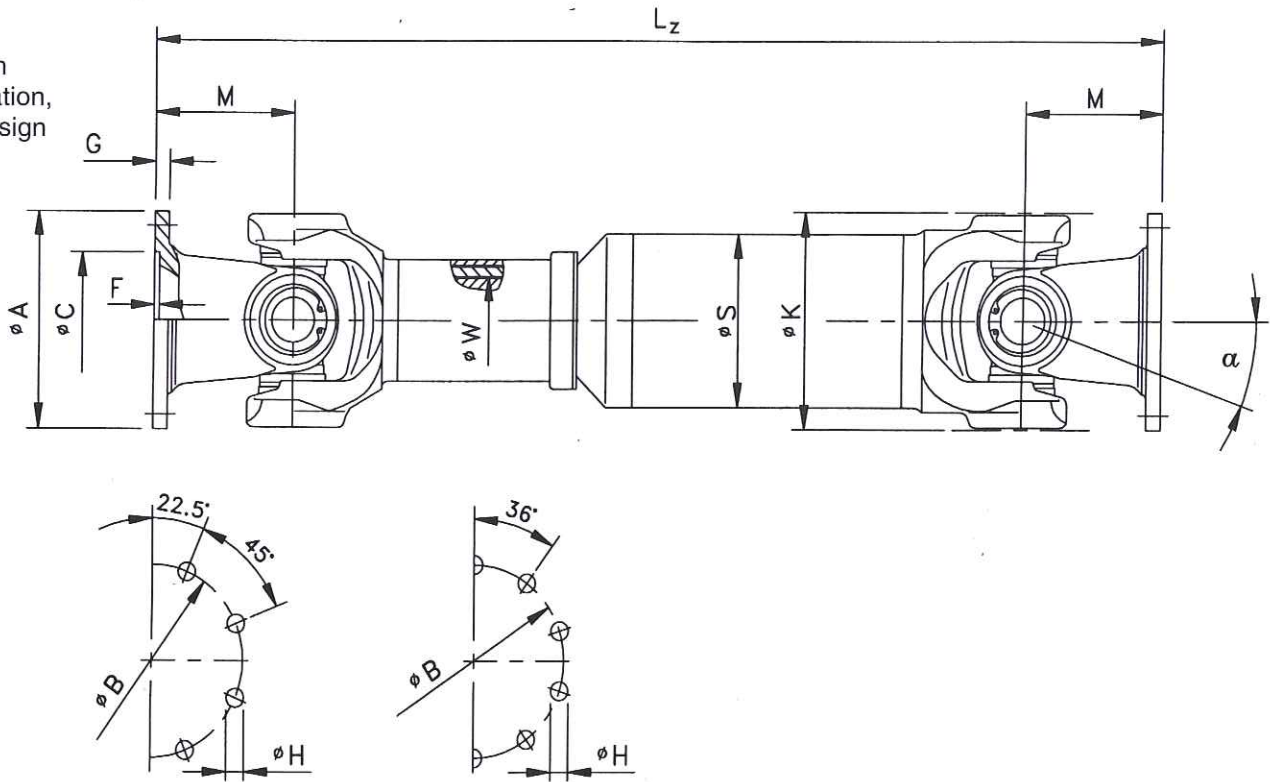

**T**  
 without length  
 compensation,  
 tubular design

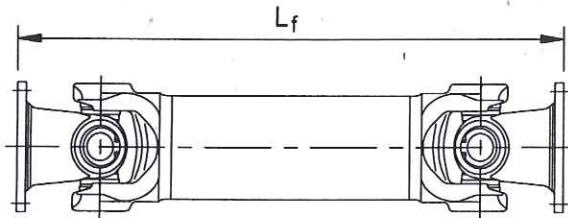

**SC1 SC2**  
**SC3 SC4**  
 with length  
 compensation,  
 short design

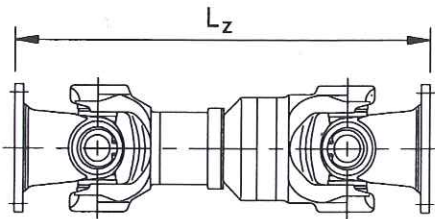

**FF**  
 without length  
 compensation,  
 double flange  
 shaft design

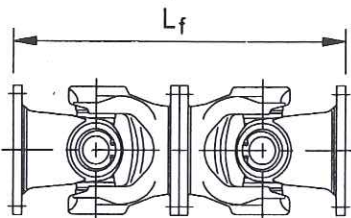



**HIGH BEARING LIFE SERIES:**

<b>MSI SERIES</b>	645180	645225	655180	655225	665180	665225	550225	550250	555250	560285
-------------------	--------	--------	--------	--------	--------	--------	--------	--------	--------	--------

**Capacity**

T <sub>FL</sub>	Nm	17000	25000	35000	43000	52000	57000
T <sub>K</sub>	Nm	13000	19000	27000	33000	40000	44000
T <sub>FT</sub>	Nm	5100	7300	11000	13000	18000	23000
T <sub>C100</sub>	Nm	4700	6000	8750	11000	17000	24000
T <sub>C1000</sub>	Nm	2350	3000	4375	6500	8500	12000

T<sub>FL</sub>= Functional Limit Torque; T<sub>K</sub>= Catalog Torque; T<sub>FT</sub>= Fatigue Torque (reversing applications)  
 T<sub>C100</sub>= Continuous Torque at 100 RPM, 3 deg and 20,000 hours B-10 Bearing Life  
 T<sub>C1000</sub>= Continuous Torque at 1000 RPM, 3 deg and 20,000 hours B-10 Bearing Life

**Dimensions:**

Flange	A	mm	180	225	180	225	180	225	225	250	250	285
Angle	α	deg	25	25	25	25	25	25	24	24	20	20
Swing	K	mm	172		178		204		215		250	265
BC	B	mm	155.5	196	155.5	196	155.5	196	196	218	218	245
Pilot	C	mm	110	140	110	140	110	140	140	140	140	175
Depth	F	mm	3	5	3	5	3	5	4.2	5.2	5.5	6
Thickness	G	mm	12	15	14	15	15	15	15	18	18	20
Boltholes	H	mm	14.1	16.1	16.1	16.1	16.1	16.1	16.1	18.1	18.1	20.1
# of bolts	I	mm	8	8	10	8	10	8	8	8	8	8
End to cl	M	mm	95	90	115	95	110	110	108	108	125	135
Tubing	S	Inch	4.750 x .188		4.750 x .250		144 x 7 mm		144 x 7 mm		6.750 x .375	6.750 x 500
Spline	W	mm	68x1.75		78x2		88x2.5		90x2.5		115x2.5	

**Length Variations [mm]:**

Design \ Series		645180	645225	655180	655225	665180	665225	550225	550250	555250	560285
TS	Min. Length	595	585	662	622	686	686	800	800	960	990
	Slip	110	110	110	110	110	110	110	110	100	100
T	Fixed Length	425	415	475	435	491	491	540	540	610	640
SC 1	Length			607			611	693			
	Slip			110			80	110			
SC 2	Length						586	650	650		
	Slip						55	90	90		
SC 3	Length	457	437	513	463	480	544	600	600	720	
	Slip	60	40	60	50	50	70	75	75	65	
SC 4	Length	507	487					550	550		
	Slip	110	100					60	60		
FF	Length L <sub>r</sub>	380	360	460	380	440	440	432	432	500	540

Please verify all drive shaft selections with MSI engineering.

Flange may have to be reinforced to transmit max. torque.

**Longer Slip** and **High Angle** version are available.

Above listed are standard metric flange patterns. **Special Flange Patterns** are available upon request.

Weights, torsional stiffness and inertia information can be supplied.

Please consult **MSI engineering**.



**TS**

with length compensation, tubular design

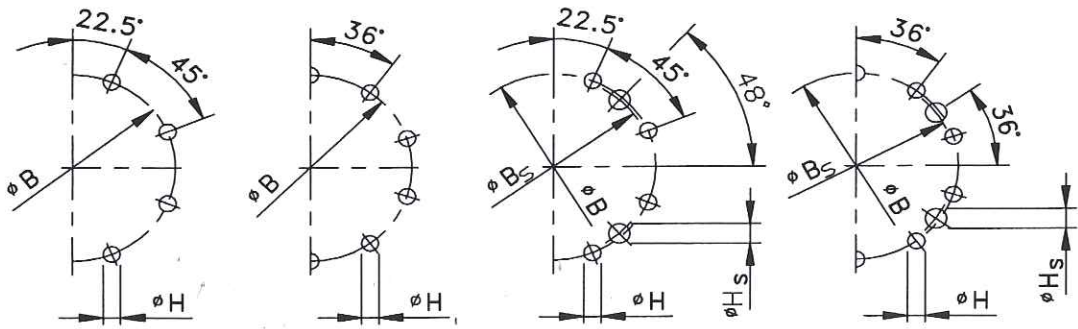
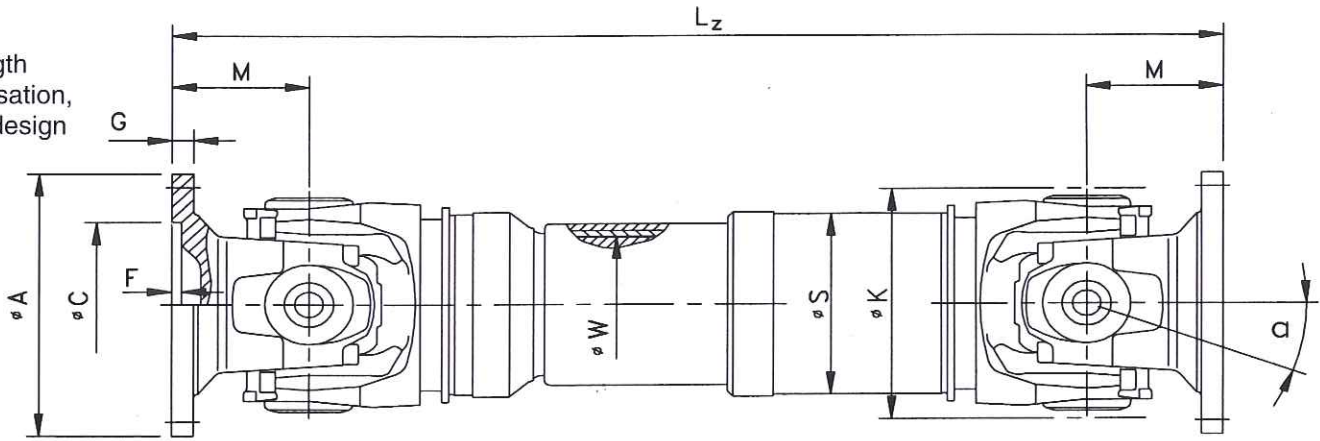

**T**

without length compensation, tubular design

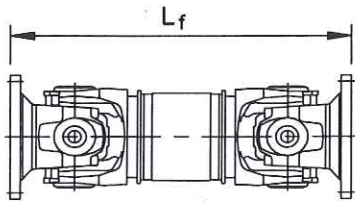

**SC1**

**SC2**

**SC3**

with length compensation, short design

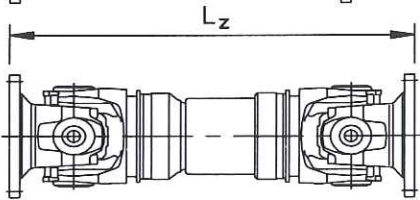

**FF**

without length compensation, double flange shaft design

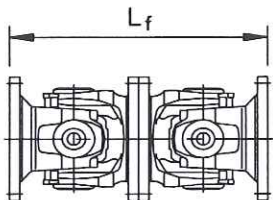



**HIGH BEARING LIFE SERIES:**

<b>MSI SERIES</b>	360285	360315	365315	365350	370350	370390	375390	375435	380435
-------------------	--------	--------	--------	--------	--------	--------	--------	--------	--------

**Capacity:**

T <sub>FL</sub>	Nm	60000	90000	130000	190000	255000
T <sub>K</sub>	Nm	47000	70000	102000	145000	195000
T <sub>FT</sub>	Nm	23000	36000	53000	75000	102000
T <sub>C100</sub>	Nm	24000	33000	48000	63000	84000
T <sub>C1000</sub>	Nm	12000	16500	24000	31500	42000

T<sub>FL</sub>= Functional Limit Torque; T<sub>K</sub>= Catalog Torque; T<sub>FT</sub>= Fatigue Torque (reversing applications)  
 T<sub>C100</sub>= Continuous Torque at 100 RPM, 3 deg and 20,000 hours B-10 Bearing Life  
 T<sub>C1000</sub>= Continuous Torque at 1000 RPM, 3 deg and 20,000 hours B-10 Bearing Life

**Dimensions:**

Flange	A	mm	285	315	315	350	350	390	390	435	435
Angle	α	deg	15	15	15	15	15	15	15	15	15
Swing	K	mm	240		265		300		330		370
BC	B	mm	245	280	280	310	310	345	345	385	385
Pilot	C	mm	175	175	175	220	220	250	250	280	280
Depth	F	mm	6	6	6	7	7	7	7	9	9
Thickness	G	mm	20	20	22	22	25	25	28	28	32
Boltholes	H	mm	20.1	22.1	22.1	22.1	22.1	24.1	24.1	27.1	27.1
# of bolts	I	mm	8	8	8	10	10	10	10	10	10
End to cl	M	mm	135	145	150	165	170	180	190		210
Tubing	S	Inch	6.750 x 500		8.750 x 500		8.750 x 750		10.750 x 500		10.750 x 750
Spline	W	mm	68x1.75		78x2		88x2.5		90x2.5		115x2.5

**Length Variations [mm]:**

Design \ Series		360285	360315	365315	365350	370350	370390	375390	375435	380435
TS	Min. Length L <sub>z</sub>	870	890	980	1010	1070	1090	1210		1280
	Slip	100	100	135	135	135	135	170		170
T	Fixed Length L <sub>r</sub>	640	660	710	740	800	820	890		960
SC 1	Length L <sub>z</sub>	843	863	953	983	1043	1063	1175		1245
	Slip	100	100	135	135	135	135	170		170
SC 2	Length L <sub>z</sub>	810	830	890	920	980	1000	1100		1170
	Slip	70	70	75	75	75	75	95		95
SC 3	Length L <sub>z</sub>	750	770	835	865	925	945	1030		1100
	Slip	65	65	75	75	75	75	85		85
FF	Length L <sub>r</sub>	540	580	600	660	680	720	760		840

Please verify all drive shaft selections with MSI engineering.  
 Flange may have to be reinforced to transmit max. torque.  
**Longer Slip** and **High Angle** versions are available.  
 Above listed are standard metric flange patterns. **Special Flange Patterns** are available upon request.  
 Weights, torsional stiffness and inertia information can be supplied.  
 Please consult **MSI engineering**.



**TS**  
with length  
compensation,  
tubular design

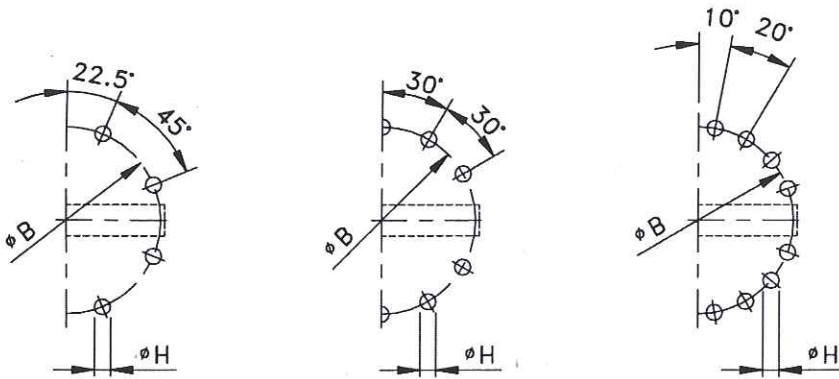
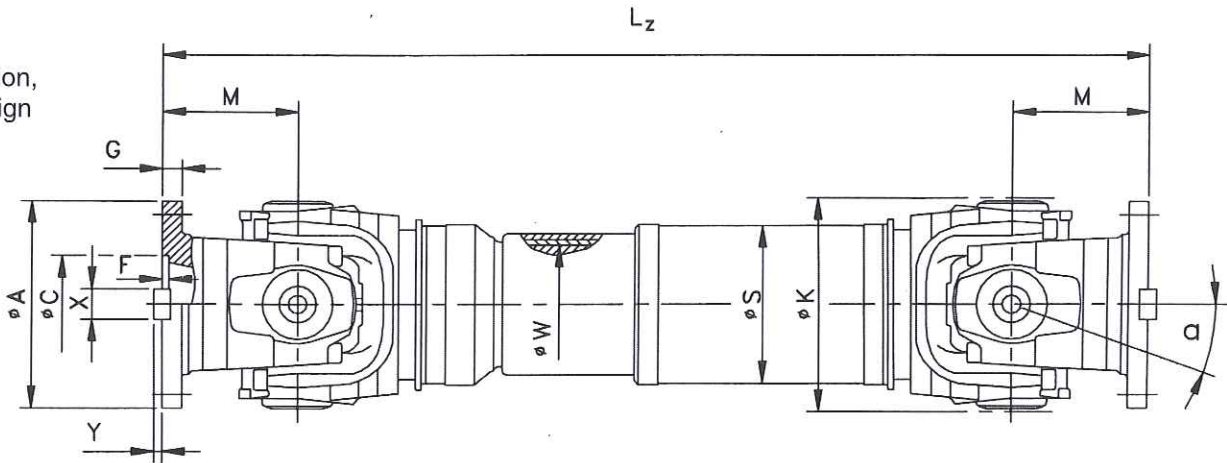

**T**  
without length  
compensation,  
tubular design

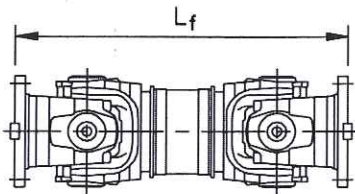

**SC1**  
**SC2**  
**SC3**  
with length  
compensation,  
short design

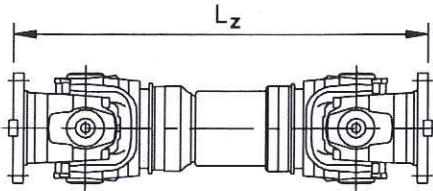

**FF**  
without length  
compensation,  
double flange  
shaft design

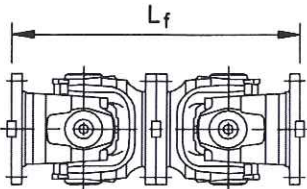



**HIGH TORQUE SERIES:**

<b>MSI SERIES</b>	250225	255250	260285	265315	270350	275390	280435	285480	290550
-------------------	--------	--------	--------	--------	--------	--------	--------	--------	--------

**Capacity:**

T <sub>FL</sub>	Nm	70000	105000	150000	215000	295000	390000	580000	750000	1150000
T <sub>K</sub>	Nm	54000	80000	117000	165000	225000	300000	450000	600000	900000
T <sub>FT</sub>	Nm	23000	36000	53000	75000	102000	140000	220000	285000	435000
T <sub>C100</sub>	Nm	17000	24300	34700	49000	65500	86000	131000	167000	254000
T <sub>C1000</sub>	Nm	8500	12150	17350	24500	32750	43000	65500	83500	127000

T<sub>FL</sub>= Functional Limit Torque; T<sub>K</sub> = Catalog Torque; T<sub>FT</sub>= Fatigue Torque (reversing applications)  
T<sub>C100</sub>= Continuous Torque at 100 RPM, 3 deg and 20,000 hours B-10 Bearing Life  
T<sub>C1000</sub>= Continuous Torque at 1000 RPM, 3 deg and 20,000 hours B-10 Bearing Life

**Dimensions:**

Flange	A	mm	225	250	285	315	350	390	435	480	550
Angle	α	deg	15	15	15	15	15	10	10	10	10
Swing	K	mm	225	250	285	315	350	390	435	480	550
BC	B	mm	196	218	245	280	310	345	385	425	492
Pilot	C	mm	105	105	125	130	155	170	190	205	250
Depth	F	mm	4.5	5	6	7	7	8	10	12	12
Thickness	G	mm	20	25	27	32	35	40	42	47	50
Boltholes	H	mm	17	19	21	23	23	25	28	31	31
# of bolts	I	mm	8	8	8	10	10	10	16	16	16
End to cl	M	mm	145	165	180	205	225	205	235	265	290
Key width	X	mm	32	40	40	40	50	70	80	90	100
Key height	Y	mm	9	12.5	15	15	16	18	20	22.5	22.5
Tubing	S	Inch	6.750 x 500	8.750 x 500	8.750 x 750	10.750 x 500	10.750 x 750	10.750 x 1.500	12.750 x 1.500	14.375 x 2.000	16.000 x 2.000
Spline	W	mm	115 x 2.5	150 x 3	150 x 3	185 x 5	185 x 5	185 x 5	210 x 5	210 x 5	240 x 5

**Length Variations [mm]:**

Design \ Series		250225	255250	260285	265315	270350	275390	280435	285480	290550
TS	Min. Length L <sub>z</sub>	890	1010	1090	1240	1310	1640	1795	2010	2185
	Slip	100	135	135	170	170	170	170	190	210
T	Fixed Length L <sub>f</sub>	660	740	820	920	990	1090	1210	1340	1490
SC 1	Length L <sub>z</sub>	863	983	1063	1205	1275	1420	1535	1780	1940
	Slip	100	135	135	170	170	170	170	190	210
SC 2	Length L <sub>z</sub>	830	920	1000	1130	1200	1300	1400	1630	1770
	Slip	70	75	75	95	95	90	90	100	100
SC 3	Length L <sub>z</sub>	770	865	945	1060	1130	1200	1300	1520	1680
	Slip	65	75	75	85	85	70	70	80	80
FF	Length L <sub>f</sub>	580	660	720	820	900	820	940	1060	1160

Please verify all drive shaft selections with MSI engineering.

Flange may have to be reinforced to transmit max. torque.

**Longer Slip** and **High Angle** version are available.

Above listed are standard metric flange patterns. **Special Flange Patterns** are available upon request.

Weights, torsional stiffness and inertia information can be supplied.

Please consult **MSI engineering**.



**COMPANION FLANGES FOR HIGH BEARING LIFE SERIES:**

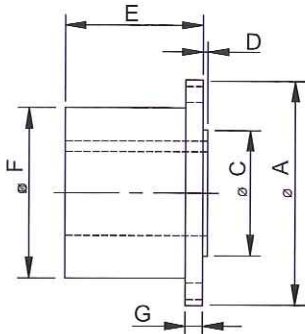

"SF" STYLE  
Standard flange

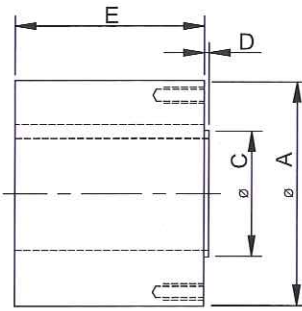

"SLF" STYLE  
Special large  
flange

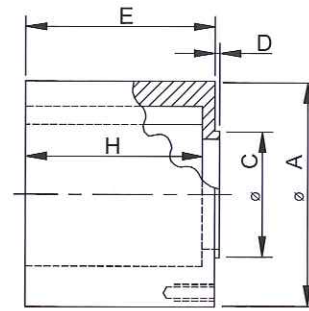

"SLFOS" STYLE  
Special large flange  
oversized

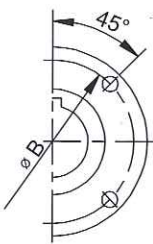

4-hole flange

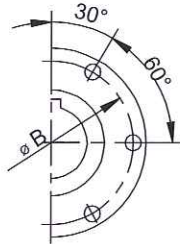

6-hole flange

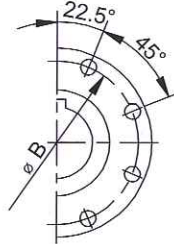

8-hole flange



10-hole flange

**Dimensions:**

Flange	A	mm	90	100	120	150	180-8	180-10	225	250	285	315	350	390	435
Bolt circle	B	mm	74.5	84	101.5	130	155.5	155.5	196	218	245	280	310	345	385
Pilot	C	mm	47	57	75	90	110	110	140	140	175	175	220	250	280
Pilot Height	D	mm	2.2	2.2	2.2	2.5	2.7	2.7	4	5	6	6	7	7	9
Hardware		mm	M8	M8	M10	M12	M14	M16	M16	M18	M20	M22	M22	M24	M27
# Bolts			4	6	8	8	8	10	8	8	8	8	10	10	10

**SF Style (Standard Flange)**

Max. Bore		In	1.562	1.750	2.188	2.875	3.500	3.500	4.500	4.937	5.562	6.500	7.250	8.250	9.125
Std Length	E	in	2.00	2.00	2.50	3.00	4.00	4.00	5.50	6.00	7.00	8.00	9.00	10.00	11.00
Hub Dia	F	in	2.417	2.562	3.250	4.312	5.187	5.125	6.687	7.437	8.406	9.687	10.88	12.09	13.47
Web	G	in	.312	.375	.375	.375	.500	.500	.625	.750	.812	.875	1.00	1.12	1.25

**SLF Style (Special Large Flange)**

Max. Bore		In	1.750	2.000	2.750	3.375	4.125	4.125	5.250	5.250	6.500	6.500	8.250	9.375	10.50
Std Length	E	in	2.50	2.50	3.00	4.00	4.50	4.50	7.25	8.25	9.375	10.25	11.25	As required	As required

**SLF-OS Style (Special Large Oversized Flange)**

Max. Bore		In	2.250	2.625	3.125	3.937	4.500	4.500	5.875	6.562	7.500	8.250	9.250	10.25	11.50
Std Length	E	in	2.50	2.50	3.00	4.00	4.50	4.50	7.25	8.25	9.375	10.25	11.25	As required	As required
Through Hole	H	In	2.375	2.375	2.875	3.750	4.250	4.250	7.00	7.875	9.000	9.875	10.75	-	-

[www.machineservice.com](http://www.machineservice.com)

24 Hour Emergency Service 920-490-7004



**COMPANION FLANGES FOR HIGH TORQUE SERIES:**

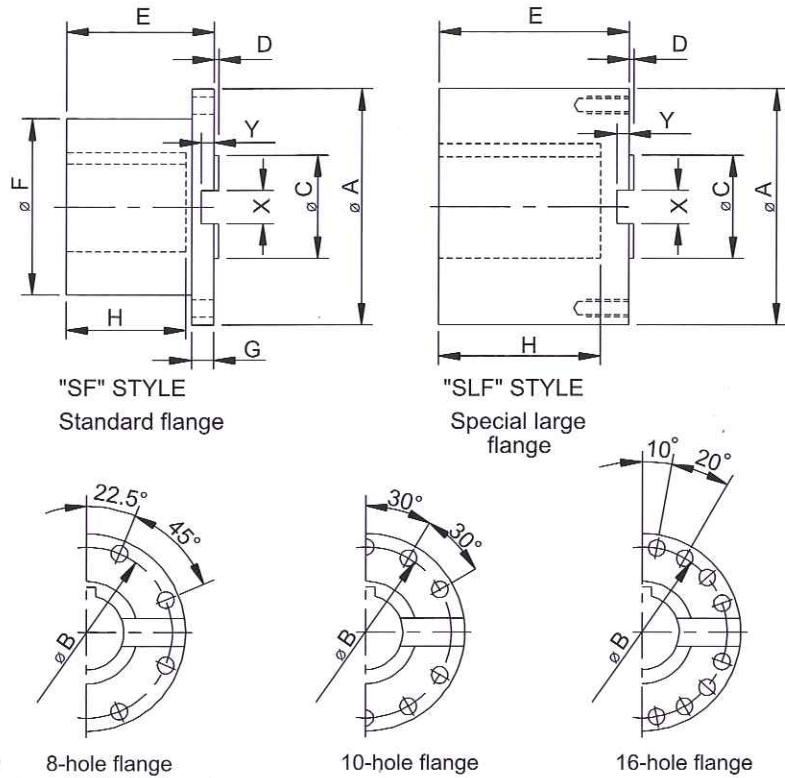

**Dimensions:**

Flange	A	mm	225	250	285	315	350	390	435	480	550
Bolt circle	B	mm	196	218	245	280	310	345	385	425	492
Pilot	C	mm	105	105	125	130	155	170	190	205	250
Pilot Height	D	mm	4.5	5	6	7	7	8	10	12	12
Hardware		mm	M16	M18	M20	M22	M22	M24	M27	M30	M30
# Bolts			8	8	8	10	10	10	16	16	16
Key Width	X	mm	32	40	40	40	50	70	80	90	100
Key Depth	Y	mm	9	12.5	15	15	16	18	20	22.5	22.5
<b>SF Style (Standard Flange)</b>											
Max. Bore		In	4.437	4.937	5.562	6.437	7.250	8.000	8.937	9.375	11.500
Std Length	E	in	5.500	6.000	7.000	8.000	9.000	10.000	11.000	As required	As required
Hub Dia.	F	in	6.687	7.437	8.375	9.656	10.843	12.078	13.453	14.844	17.484
Web	G	in	.812	1.000	1.062	1.250	1.375	1.625	1.687	1.875	2.000
Through Hole	H	In	4.63	5.000	5.875	6.875	7.875	8.750	9.687	-	-
<b>SLF Style (Special Large Flange)</b>											
Max. Bore		In	5.875	6.625	7.500	8.250	9.125	10.250	11.375	12.500	14.250
Std Length	E	in	7.375	8.000	9.000	10.000	11.000	12.000	12.000	As required	As required
Through Hole	H	In	6.500	7.000	7.875	8.875	9.875	10.750	10.688	-	-



**Formulas:**

Torque = HP \* 5252/RPM [lbs\*ft]

= HP \* 7122/RPM [Nm]

Offset (parallel) =  $\tan^{-1} (z / l-2M)$  [deg]

With l = distance between shaft ends  
 z = offset from driver centerline  
 M = center of joint to end of flange

Roll Speed =  $S_L * 3.8197 / D$  [RPM]

With  $S_L$  = Line or machine speed [ft/min]  
 D = roll diameter [inch]

**Conversion Factors:**

FROM	TO	MULTIPLY BY	FROM	TO	MULTIPLY BY
<b>Ft*lbs</b>	Nm	1.356	<b>Nm</b>	Ft*lbs	0.7375
<b>Ft*lbs</b>	Inch*lbs	12	<b>Inch*lbs</b>	Ft*lbs	0.08333
<b>Hp</b>	kW	.7457	<b>kW</b>	Hp	1.341
<b>Inch</b>	mm	25.4	<b>mm</b>	Inch	0.03937
<b>mm</b>	meter	1000	<b>meter</b>	mm	0.001
<b>kg</b>	lbs	2.205	<b>lbs</b>	kg	0.4535
<b>gallon</b>	liter	3.785	<b>liter</b>	gallon	0.2642
<b>radian</b>	degree	57.2958	<b>degree</b>	radian	0.17453
<b>Lbs*ft<sup>2</sup></b>	Lbs*inch <sup>2</sup>	144	<b>Lbs*inch<sup>2</sup></b>	Lbs*ft <sup>2</sup>	0.006944
<b>Kg*m<sup>2</sup></b>	Lbs*ft <sup>2</sup>	23.7344	<b>Lbs*ft<sup>2</sup></b>	Kg*m <sup>2</sup>	0.042133

