

Parts List 248 Series

Effective: June 15, 2010

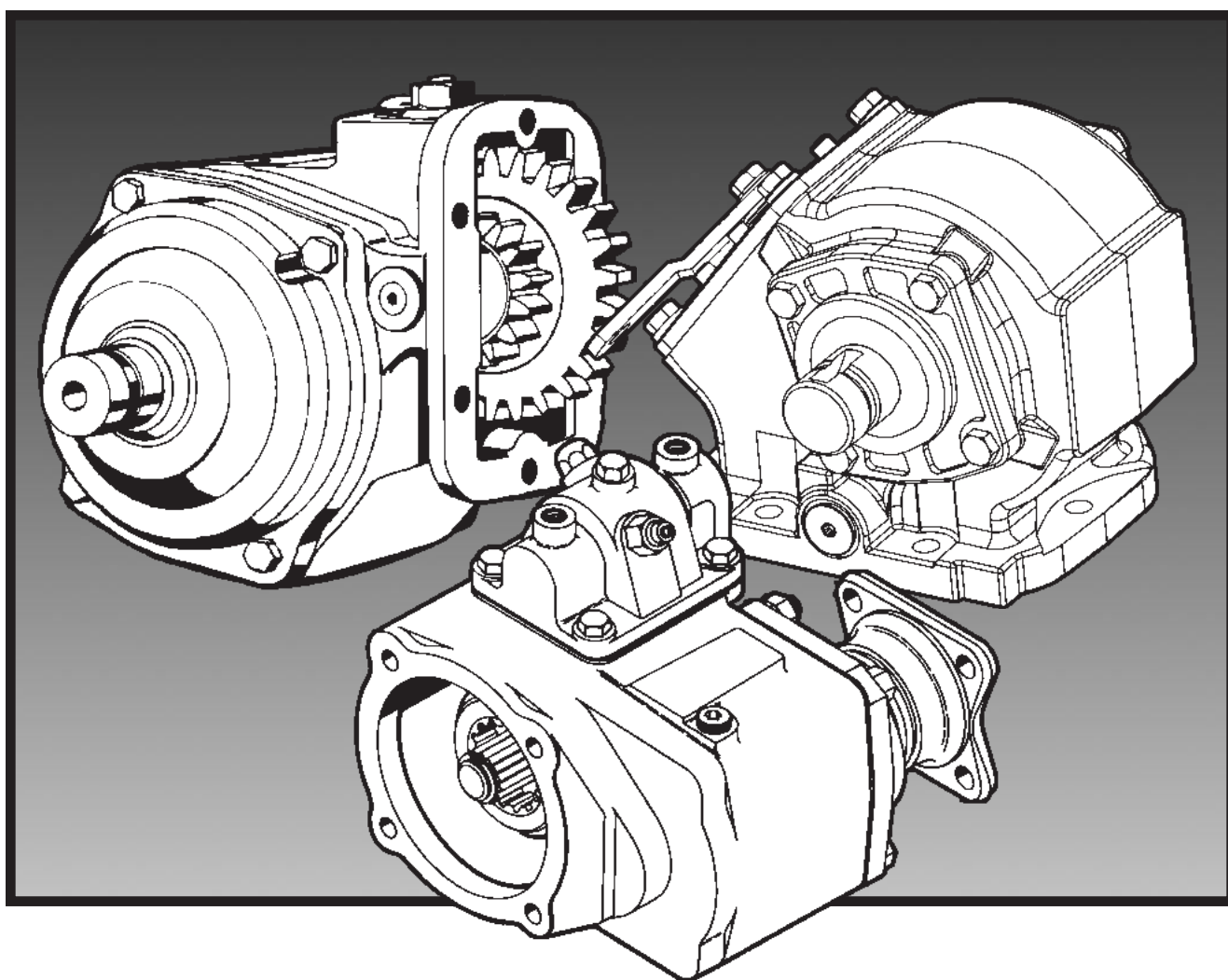



WARNING — User Responsibility

FAILURE OR IMPROPER SELECTION OR IMPROPER USE OF THE PRODUCTS DESCRIBED HEREIN OR RELATED ITEMS CAN CAUSE DEATH, PERSONAL INJURY AND PROPERTY DAMAGE.

This document and other information from Parker-Hannifin Corporation, its subsidiaries and authorized distributors provide product or system options for further investigation by users having technical expertise.

The user, through its own analysis and testing, is solely responsible for making the final selection of the system and components and assuring that all performance, endurance, maintenance, safety and warning requirements of the application are met. The user must analyze all aspects of the application, follow applicable industry standards, and follow the information concerning the product in the current product catalog and in any other materials provided from Parker or its subsidiaries or authorized distributors.

To the extent that Parker or its subsidiaries or authorized distributors provide component or system options based upon data or specifications provided by the user, the user is responsible for determining that such data and specifications are suitable and sufficient for all applications and reasonably foreseeable uses of the components or systems.

Offer of Sale

The items described in this document are hereby offered for sale by Parker Hannifin Corporation, its subsidiaries or its authorized distributors. This offer and its acceptance are governed by the provisions stated in the "Offer of Sale".

© Copyright 2010, Parker Hannifin Corporation, All Rights Reserved

Contents

Exploded View 1

Bill of Materials 2-3

Driveshaft & Clutch Assembly Exploded View 4

Valve Cap Assembly Exploded View 5

Model Number Designation and Housing Dimensions 6

Offer of Sale 8

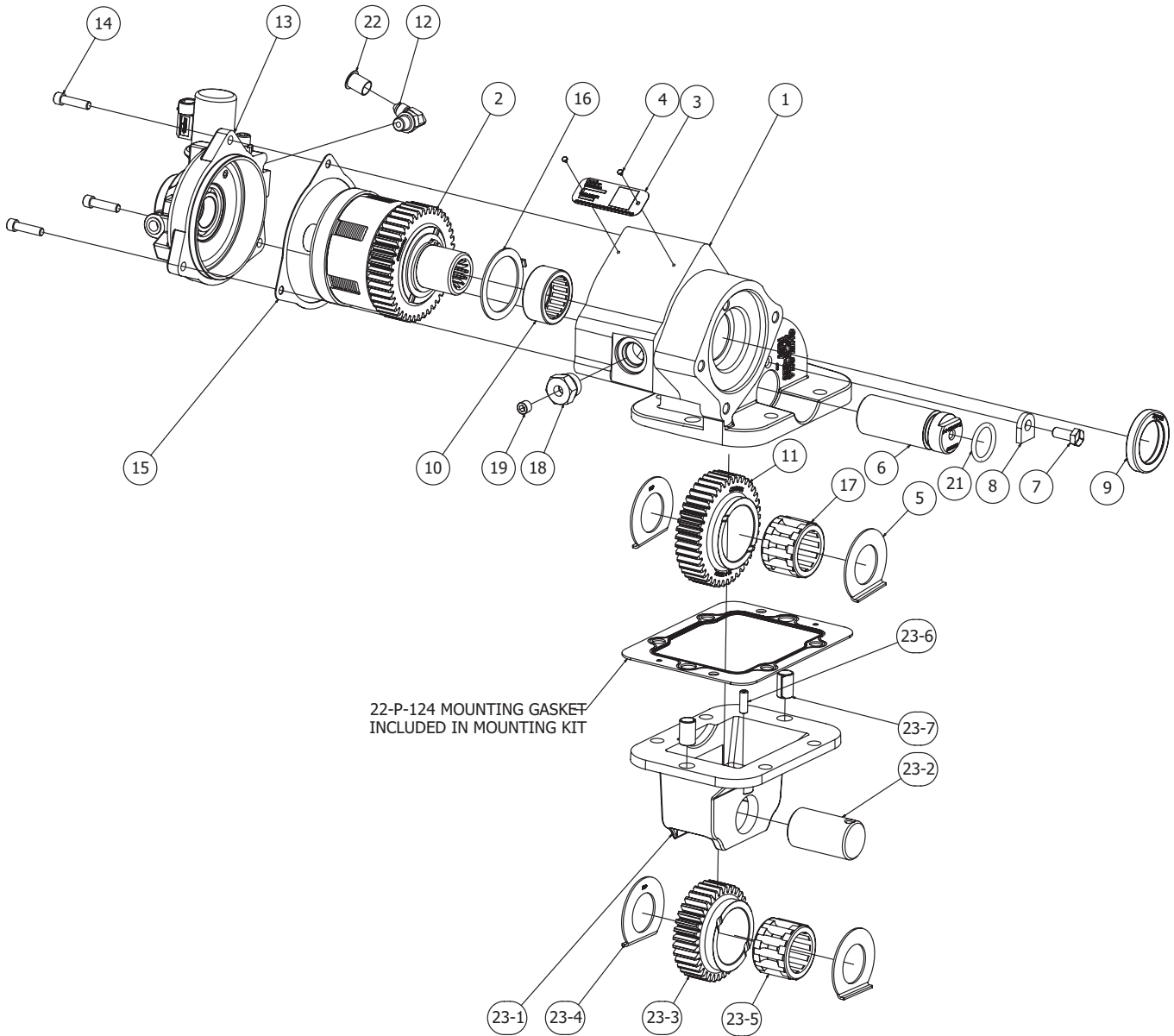

Bill of Materials

Item	Part Number	Description	Quantity
1	1-P-627	Housing 248.....	1
2	329604-1X	Ass'y Drive Shaft & Clutch ("XD" Output).....	1 or
	329604-2X	Ass'y Drive Shaft & Clutch ("XP" Output).....	1 or
	329604-3X	Ass'y Drive Shaft & Clutch ("AD" Output).....	1 or
	329604-4X	Ass'y Drive Shaft & Clutch ("XE" Output).....	1
3	68-P-51	Plate Name	1
4	378422	Screw Drive	2
5	31-P-135	Washer Thrust 1.280" x 2.300" x .064"	2
6	9-P-101	Shaft Idler 1.26".....	1
7	378430-8	Capscrew HH .312"-18 x .750".....	1
8	27-P-9	Plate Lock.....	1
9	28-P-225	Oil Seal 2.004" x 1.375" x .315"	1
10	561030	Bearing Needle Roller Ass'y 1.375" x 1.750 x .75"	1
11	33-P-76	Gear Reverse Idler 41T.....	1
12	379486	Elbow 90° .438" - 20.....	1
13	329614X	Ass'y Valve Cap.....	1
13-1	28-P-119	Oil Seal 1.379" x .875" x .250"	1
13-2	378811	Plate Seal Backup.....	1
13-3	378849	Lockring.....	1
13-4	380011-12	Cartridge Valve Non Regulating 12V.....	1
13-5	21-P-720	Cap Valve Cap.....	1
13-6	379484	Plug O-Ring Boss .438" - 20	1
13-7	378447-4	Capscrew SH .312" - 18 x .750"	1
13-8	500897-5	Plug Shipping.....	1
13-9	561031	Bearing Ball .9843" x 1.8504" x .4724"	1
14	379431-6	Capscrew SH .250" - 20 x 1.000"	3
15	22-P-123	Gasket Valve Cap.....	1
16	31-P-119	Washer Thrust 1.800" x 2.300" x .064"	1
17	561029	Bearing Needle Roller Ass'y 1.26" x 1.811" x 1.26"	1
18	379242	Adapter Straight .125" - 27 x .750" - 16.....	1
19	379231	Plug Pipe .125" - 27	1
20	500007-29	Key Woodruff ("XD" Output Only)	1
21	28-P-247	O-Ring .984" x .139"	1
22	379564-2	Cap Shipping.....	1
23	32961X	Ass'y Adapter	1
23-1	42-P-236	Body Adapter 248	1
23-2	9-P-100	Shaft Idler 1.26".....	1
23-3	5-P-1436	Gear Input 35T.....	1
23-4	31-P-135	Washer Thrust 1.280" x 2.300" x .064"	2
23-5	561029	Bearing Needle Roller Ass'y 1.26" x 1.811" x 1.26"	1
23-6	378452-10	Setscrew .250" - 20 x .750"	1
23-7	385078	Dowel Bushing 10.87" x 13.01" x 20	2
24	28-P-171	O-Ring .644" x .087" (E.O.C. Only)	1
25	379243	Sensor Speed (E.O.C. Only)	1
		Loose Parts	
	329248-5X	Kit Installation & Label.....	1
	328946X	Kit Caution Labels.....	1
	379085-2	Label Instruction P.T.O. Shifting	1
	379624	Warranty Card.....	1
	69-P-12	Label Caution.....	1
	22-P-124	Gasket Mounting.....	1
	HY25-1002-M1/US	Safety Statement.....	1
	HY25-1248-M1/US	Owners Manual.....	1
	379688	Spline Lube	1
	329651X	Kit Installation & Mounting Non E.O.C. ("B" Shift Option)	1
	379502	Pressure Switch	1
	379698	Elbow Male 90° .438" - 24 x .125" - 27	1
	380089	Adapter M10 x .125" - 27	1

Bill of Materials

Item	Part Number	Description	Quantity
	379817	Grommet	1
	329232-1X	Hose Assembly	1
	8000-21X	P.T.O. Mounting Stud Kit.....	1
	379744	Flange Nut .375" (3/8)" - 24.....	3
	380073	Bolt Flange Hex Head M10 x 1.5" - 45mm.....	3
	379428-18	Metric Stud M10 - 1.5" x 3.75" - 24 x 2.0"	1
	379428-24	Metric Stud M10 - 1.5" x 3.75" - 24 x 2.375"	2
	69-P-13	Label Caution.....	1
	329616X	Wiring Harness Non E.O.C.	1
	329650X	Ass'y Speed Limiter ("K" Shift Option).....	1
	329652X	Kit Installation & Mounting E.O.C. ("K" Shift Option)	1
	329617X	Wiring Harness E.O.C.....	1
	379502	Pressure Switch	1
	379698	Elbow Male 90° .438" 24 x .125" - 27.....	1
	380089	Adapter M10 x .125" - 27	1
	379817	Grommet	1
	329232-1X	Hose Assembly	1
	8000-21X	P.T.O. Mounting Stud Kit.....	1
	379744	Flange Nut .375" (3/8)" - 24.....	3
	380073	Bolt Flange Hex Head M10 x 1.5" - 45mm.....	3
	379428-18	Metric Stud M10 - 1.5 x 3.75" - 24 x 2.0"	1
	379428-24	Metric Stud M10 - 1.5 x 3.75" - 24 x 2.375"	2
	69-P-13	Label Caution.....	1
		Service Kits	
	329248-1X	Kit Gasket & Seal	
	28-P-247	O-Ring .984" x .139"	1
	22-P-123	Gasket Valve	1
	28-P-289	O-Ring .864" x .070"	2
	28-P-288	O-Ring 3.234" x .139"	1
	378576	Lockring	1
	379693	Lockring	1
	329248-2X	Kit Bearing	
	561029	Bearing Needle Roller Ass'y 1.26" x 1.811" x 1.26".....	2
	561030	Bearing Needle Roller Ass'y 1.375" x 1.750" x .75".....	1
	561031	Bearing Ball .9843" x 1.8504" x .4724"	1
	561032	Bearing Plain 1.378" x 1.535" x 1.18"	1
	329248-3X	Kit Clutch Repair	
	379691	Disc Friction	9
	380060	Plate Clutch.....	8
	329248-4X	Kit Complete Rebuild (Includes 329248-1X,-2X,-3X,-4X)	
	329248-1X	Kit Gasket.....	1
	329248-2X	Kit Bearing	1
	329248-3X	Kit Clutch.....	1
	329376-5X	Kit Soft Goods Service Kit, CGP-P11 Pump	
	8611-023-Q1N	Soft Goods	1
	28-P-276	O-Ring 1.674" x .103"	1
	379688	Lubricant Spline	1

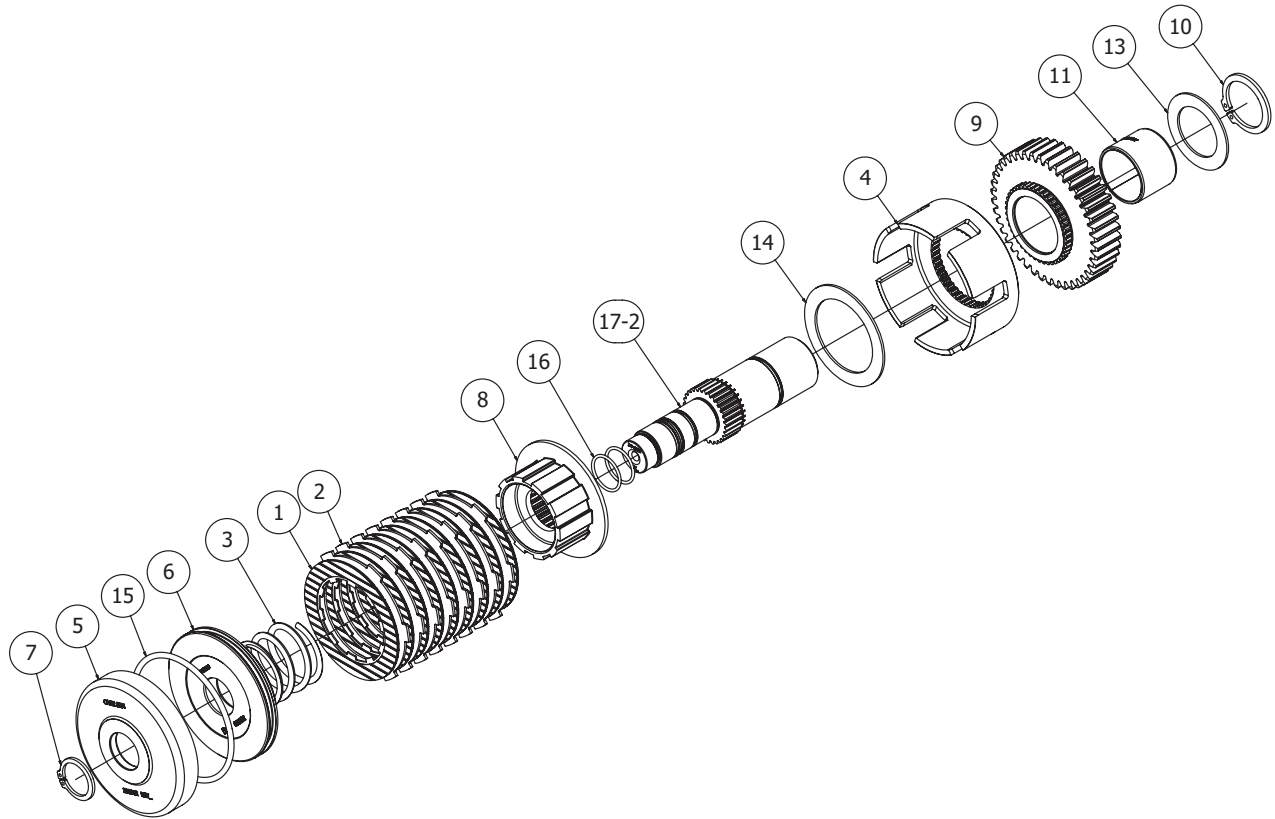

Drive Shaft & Clutch Assembly

Item	Part Number	Description	Quantity
	329604-1X	Ass'y Drive Shaft & Clutch ("XD" Output).....	1
	329604-2X	Ass'y Drive Shaft & Clutch ("XP" Output).....	1
	329604-3X	Ass'y Drive Shaft & Clutch ("AD" Output).....	1
	329604-4X	Ass'y Drive Shaft & Clutch ("XE" Output).....	1
1	379691	Disc Friction	9
2	380060	Plate Clutch	8
3	37-P-56	Spring 1.75" x 1.51"	14
	380061	Gear Bell - 42 Teeth	1
5	380062	Cylinder Clutch.....	1
6	380063	Piston Clutch.....	1
7	379693	Lockring	1
8	2-P-860	Clutch Hub - 29 Teeth	1
9	2-P-861	Gear Output - 42 Teeth	1
10	378576	Lockring	1
11	561032	Bearing Plain - 1.378" x 1.535" x 1.18".....	1
13	31-P-90	Washer Thrust - 1.382" x 2.730" x .062"	1
14	31-P-92	Washer Thrust - 2.007" x 2.730" x .062".....	1
15	28-P-288	O-Ring 3.234" x .139"	1
16	28-P-289	O-Ring .864" x .070"	2
17-1	3-P-1002	Shaft Output ("XD" Output 1.25" Keyed).....	1 or
17-2	3-P-1003	Shaft Output ("XP" Output 7/8" - 13T).....	1 or
17-3	3-P-1004	Shaft Output ("AD" Output 3/4" - 11T).....	1 or
17-4	3-P-1005	Shaft Output ("XE" Output 5/8" - 9T).....	1

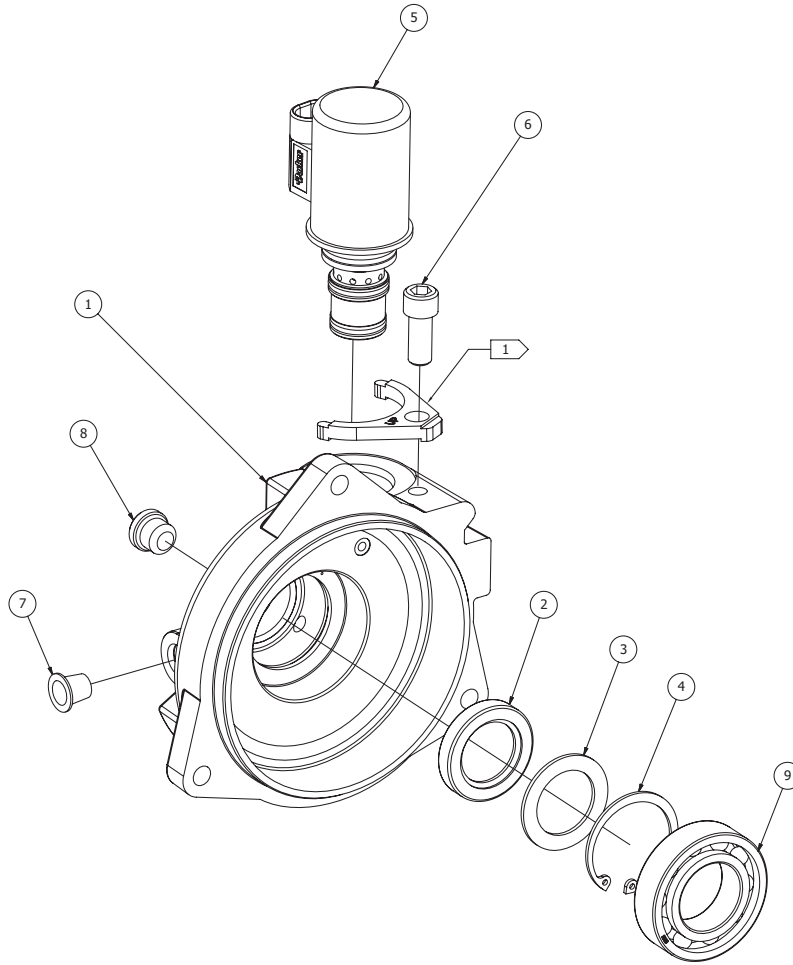

Valve Cap Assembly

Item	Part Number	Description	Quantity
	329614X	Valve Cap Assembly	
1	21-P-720	Cap, Valve	1
2	28-P-119	Oil Seal 1.379" x .875" x .250"	1
3	378811	Plate Seal Backup.....	1
4	378849	Lockring	1
5	380011-12	Cartridge Valve Non Regulating 12V	1
6	378447-4	Capscrew Socket Head .312" - 18 x .750"	1
7	500897-5	Plug Shipping.....	1
8	379484	Plug O-Ring Boss .438" - 20.....	1
9	561031	Bearing, Ball .9843" x 1.8504" x .4724"	1

Model Number Designation

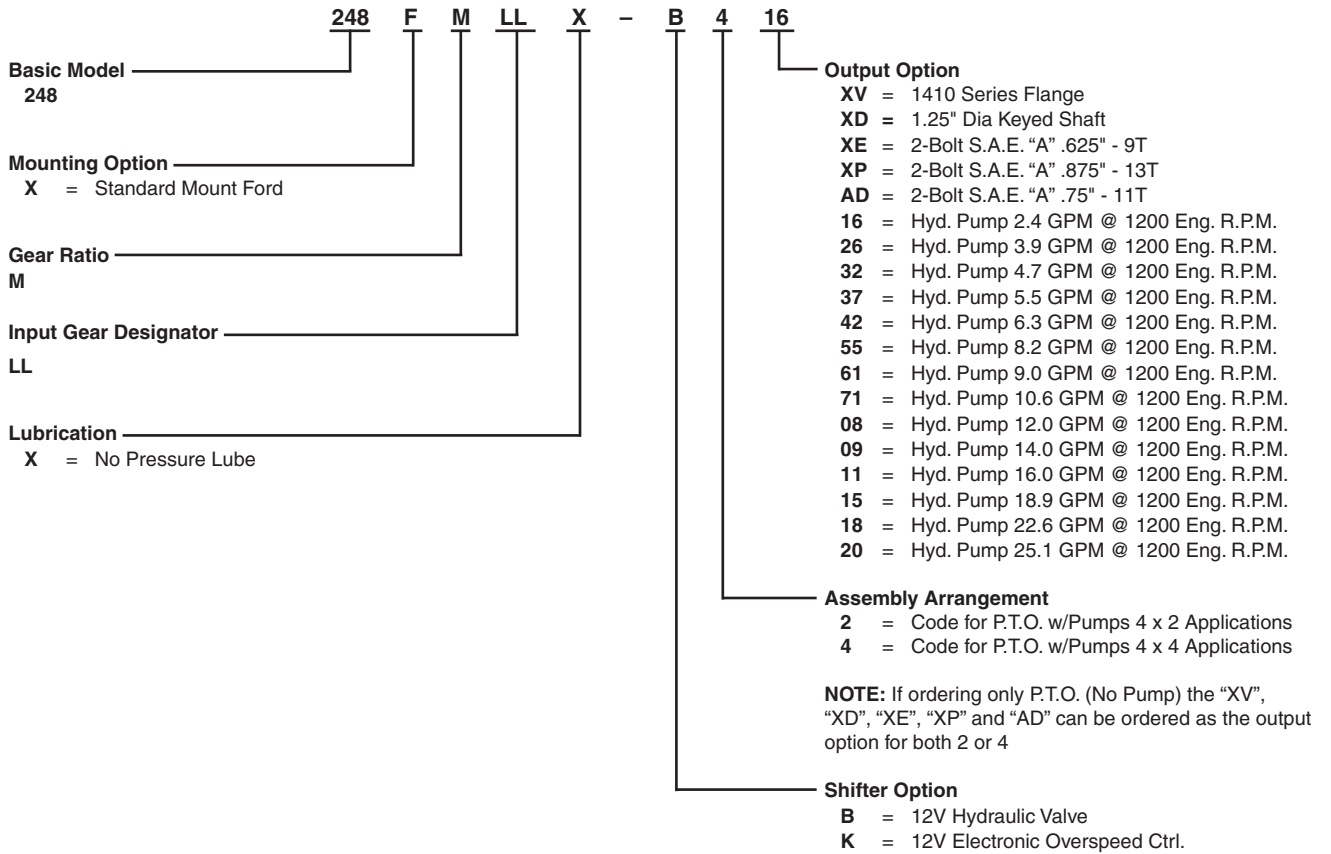

Housing Dimensions

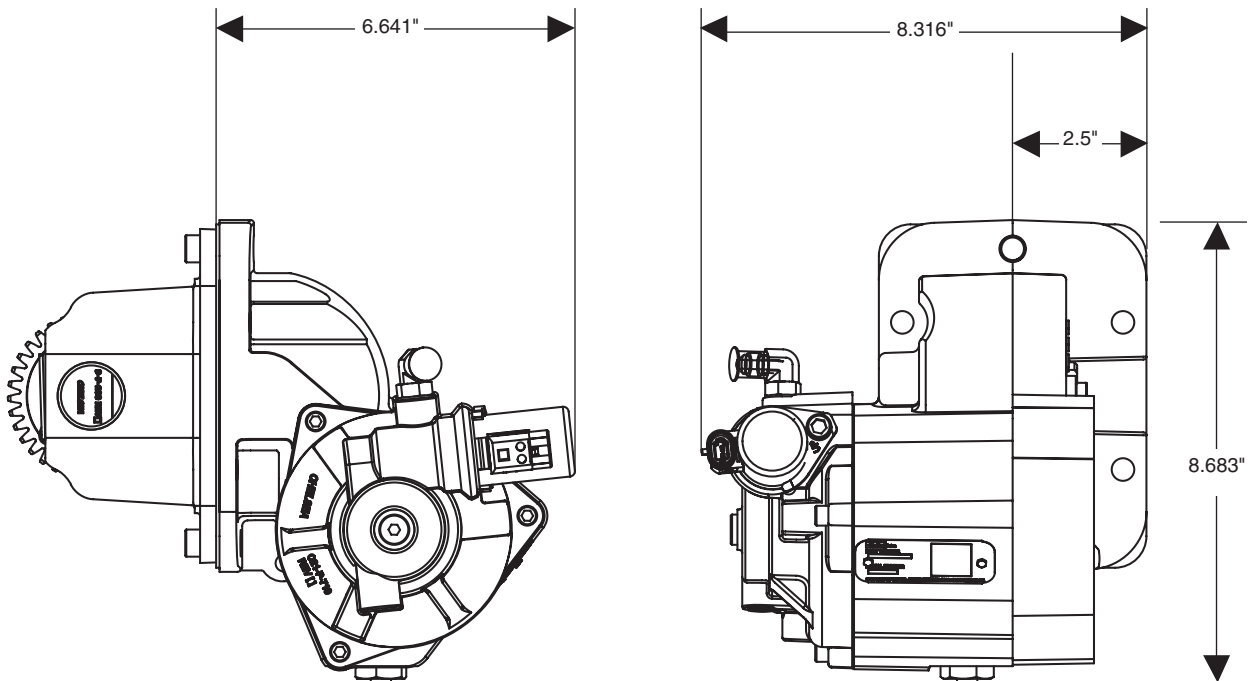

Offer of Sale

The items described in this document and other documents or descriptions provided by Parker Hannifin Corporation, its subsidiaries and its authorized distributors are hereby offered for sale at prices to be established by Parker Hannifin Corporation, its subsidiaries and its authorized distributors. This offer and its acceptance by any customer ("Buyer") shall be governed by all of the following Terms and Conditions. Buyer's order for any such items, when communicated to Parker Hannifin Corporation, its subsidiary or an authorized distributor ("Seller") verbally or in writing, shall constitute acceptance of this offer.

1. Terms and Conditions of Sale: All descriptions, quotations, proposals, offers, acknowledgments, acceptances and sales of Seller's products are subject to and shall be governed exclusively by the terms and conditions stated herein. Buyer's acceptance of any offer to sell is limited to these terms and conditions. Any terms or conditions in addition to, or inconsistent with those stated herein, proposed by Buyer in any acceptance of an offer by Seller, are hereby objected to. No such additional, different or inconsistent terms and conditions shall become part of the contract between Buyer and Seller unless expressly accepted in writing by Seller. Seller's acceptance of any offer to purchase by Buyer is expressly conditional upon Buyer's assent to all the terms and conditions stated herein, including any terms in addition to, or inconsistent with those contained in Buyer's offer. Acceptance of Seller's products shall in all events constitute such assent.

2. Payment: Payment shall be made by Buyer net 30 days from the date of delivery of the items purchased hereunder. Amounts not timely paid shall bear interest at the maximum rate permitted by law for each month or portion thereof that the Buyer is late in making payment. Any claims by Buyer for omissions or shortages in a shipment shall be waived unless Seller receives notice thereof within 30 days after Buyer's receipt of the shipment.

3. Delivery: Unless otherwise provided on the face hereof, delivery shall be made F.O.B. Seller's plant. Regardless of the method of delivery, however, risk of loss shall pass to Buyer upon Seller's delivery to a carrier. Any delivery dates shown are approximate only and Seller shall have no liability for any delays in delivery.

4. Warranty: Seller warrants that certain Products, namely PTOs, SEMs, and Wet Line Kits sold hereunder shall be free from defects in material or workmanship for a period of twenty four months from the date of delivery to Buyer. Seller warrants that certain Products namely Pumps, and Hydraulic Accessories shall be free from defects in material or workmanship for a period of eighteen months from the date of delivery to the Buyer. The prices charged for Seller's products are based upon the exclusive limited warranty stated above, and upon the following disclaimer: **DISCLAIMER OF WARRANTY: THIS WARRANTY COMPRISES THE SOLE AND ENTIRE WARRANTY PERTAINING TO PRODUCTS PROVIDED HEREUNDER. SELLER DISCLAIMS ALL OTHER WARRANTIES, EXPRESS AND IMPLIED, INCLUDING MERCHANTABILITY AND FITNESS FOR A PARTICULAR PURPOSE.**

5. Limitation Of Remedy: SELLER'S LIABILITY ARISING FROM OR IN ANYWAY CONNECTED WITH THE ITEMS SOLD OR THIS CONTRACT SHALL BE LIMITED EXCLUSIVELY TO REPAIR OR REPLACEMENT OF THE ITEMS SOLD OR REFUND OF THE PURCHASE PRICE PAID BY BUYER, AT SELLER'S SOLE OPTION. IN NO EVENT SHALL SELLER BE LIABLE FOR ANY INCIDENTAL, CONSEQUENTIAL OR SPECIAL DAMAGES OF ANY KIND OR NATURE WHATSOEVER, INCLUDING BUT NOT LIMITED TO LOST PROFITS ARISING FROM OR IN ANYWAY CONNECTED WITH THIS AGREEMENT OR ITEMS SOLD HEREUNDER, WHETHER ALLEGED TO ARISE FROM BREACH OF CONTRACT, EXPRESS OR IMPLIED WARRANTY, OR IN TORT, INCLUDING WITHOUT LIMITATION, NEGLIGENCE, FAILURE TO WARN OR STRICT LIABILITY.

6. Changes, Reschedules and Cancellations: Buyer may request to modify the designs or specifications for the items sold hereunder as well as the quantities and delivery dates thereof, or may request to cancel all or part of this order, however, no such requested modification or cancellation shall become part of the contract between Buyer and Seller unless accepted by Seller in a written amendment to this Agreement. Acceptance of any such requested modification or cancellation shall be at Seller's discretion, and shall be upon such terms and conditions as Seller may require.

7. Special Tooling: A tooling charge may be imposed for any special tooling, including without limitation, dies, fixtures, molds and patterns, acquired to manufacture items sold pursuant to this contract. Such special tooling shall be and remain Seller's property notwithstanding payment of any charges by Buyer. In no event will Buyer acquire any interest in apparatus belonging to Seller which is utilized in the manufacture of the items sold hereunder, even if such apparatus has been specially converted or adapted for such manufacture and notwithstanding any charges paid by Buyer. Unless otherwise agreed, Seller shall have the right to alter, discard or otherwise dispose of any special tooling or other property in its sole discretion at any time.

8. Buyer's Property: Any designs, tools, patterns, materials, drawings, confidential information or equipment furnished by Buyer or any other items which become Buyer's property, may be considered obsolete and may be destroyed by Seller after two (2) consecutive years have elapsed without Buyer placing an order for the items which are manufactured using such property, Seller shall not be responsible for any loss or damage to such property while it is in Seller's possession or control.

9. Taxes: Unless otherwise indicated on the face hereof, all prices and charges are exclusive of excise, sales, use, property, occupational or like taxes which may be imposed by any taxing authority upon the manufacture, sale or delivery of the items sold hereunder. If any such taxes must be paid by Seller or if Seller is liable for the collection of such tax, the amount thereof shall be in addition to the amounts for the items sold. Buyer agrees to pay all such taxes or to reimburse Seller therefore upon receipt of its invoice. If Buyer claims exemption from any sales, use or other tax imposed by any taxing authority, Buyer shall save Seller harmless from and against any such tax, together with any interest or penalties thereon which may be assessed if the items are held to be taxable.

10. Indemnity For Infringement of Intellectual Property Rights: Seller shall have no liability for infringement of any patents, trademarks, copyrights, trade dress, trade secrets or similar rights except as provided in this Part 10. Seller will defend and indemnify Buyer against allegations of infringement of U.S. Patents, U.S. Trademarks, copyrights, trade dress and trade secrets (hereinafter 'Intellectual Property Rights'). Seller will defend at its expense and will pay the cost of any settlement or damages awarded in an action brought against Buyer based on an allegation that an item sold pursuant to this contract infringes the Intellectual Property Rights of a third party. Seller's obligation to defend and indemnify Buyer is contingent on Buyer notifying Seller within ten (10) days after Buyer becomes aware of such allegations of infringement, and Seller having sole control over the defense of any allegations or actions including all negotiations for settlement or compromise. If an item sold hereunder is subject to a claim that it infringes the Intellectual Property Rights of a third party, Seller may, at its sole expense and option, procure for Buyer the right to continue using said item, replace or modify said item so as to make it noninfringing, or offer to accept return of said item and return the purchase price less a reasonable allowance for depreciation. Notwithstanding the foregoing, Seller shall have no liability for claims of infringement based on information provided by Buyer, or directed to items delivered hereunder for which the designs are specified in whole or part by Buyer, or infringements resulting from the modification, combination or use in a system of any item sold hereunder. The foregoing provisions of this Part 10 shall constitute Seller's sole and exclusive liability and Buyer's sole and exclusive remedy for infringement of Intellectual Property Rights.

If a claim is based on information provided by Buyer or if the design for an item delivered hereunder is specified in whole or in part by Buyer, Buyer shall defend and indemnify Seller for all costs, expenses or judgments resulting from any claim that such item infringes any patent, trademark, copyright, trade dress, trade secret or any similar right.

11. Force Majeure: Seller does not assume the risk of and shall not be liable for delay or failure to perform any of Seller's obligations by reason of circumstances beyond the reasonable control of Seller (hereinafter 'Events of Force Majeure'). Events of Force Majeure shall include without limitation, accidents, acts of God, strikes or labor disputes, acts, laws, rules or regulations of any government or government agency, fires, floods, delays or failures in delivery of carriers or suppliers, shortages of materials and any other cause beyond Seller's control.

12. Entire Agreement/Governing Law: The terms and conditions set forth herein, together with any amendments, modifications and any different terms or conditions expressly accepted by Seller in writing, shall constitute the entire Agreement concerning the items sold, and there are no oral or other representations or agreements which pertain thereto. This Agreement shall be governed in all respects by the law of the State of Ohio. No actions arising out of the sale of the items sold hereunder or this Agreement may be brought by either party more than two (2) years after the cause of action accrues.

10/09-P



Parker Hannifin Corporation
Chelsea Products Division
8225 Hacks Cross Road
Olive Branch, Mississippi 38654 USA
Tel: (662) 895-1011
Fax: (662) 890-5379
www.parker.com/chelsea

TG 06/10