

STYLE 1

U-JOINT INFORMATION AS NEEDED

STYLE 2

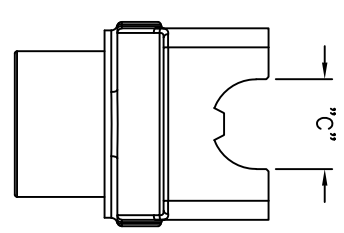
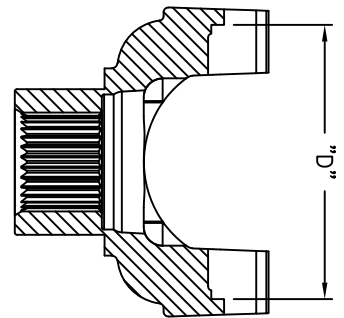

"C" = CAP DIAMETER
"D" = STACK

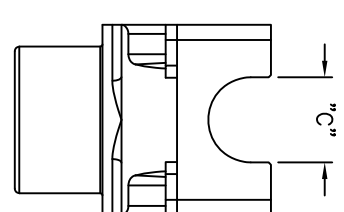
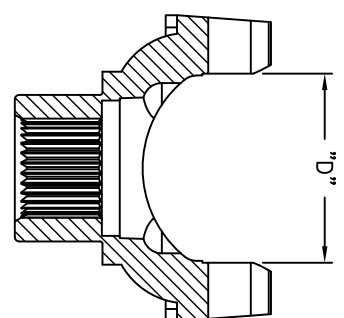

"C" = _____
"D" = _____

OUTSIDE SNAP RING

INSIDE SNAP RING

TRANSMISSION MODEL

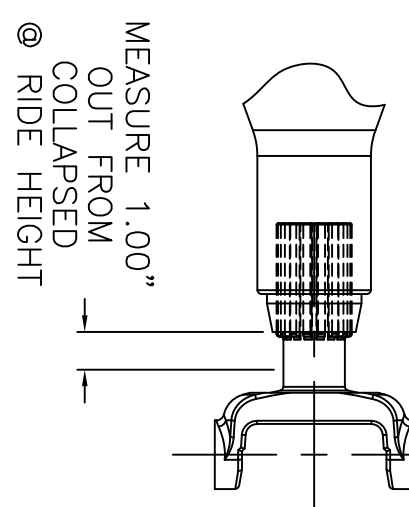

MEASURE 1.00"
OUT FROM
COLLAPSED
@ RIDE HEIGHT

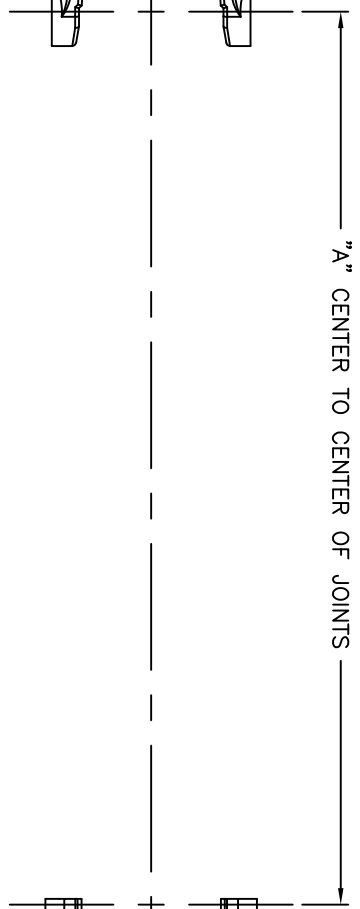

"A" CENTER TO CENTER OF JOINTS

DIFFERENTIAL MODEL

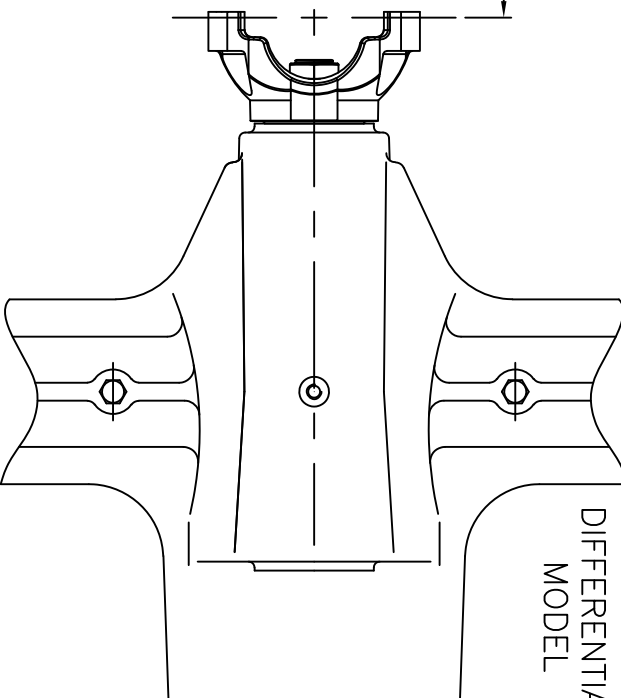

"A" = _____
TUBE DIA. = _____
MAX. RPM. OF SHAFT = _____

MSI Industrial Division
Machine Service, Inc.

THIS PRINT IS LOANED ON A CONFIDENTIAL BASIS SUBJECT TO RETURN UPON DEMAND BY MACHINE SERVICE INC. AND NOTHING MAY BE REPRODUCED, USED, OR DISCLOSED IN WHOLE OR IN PART WITHOUT THE PRIOR WRITTEN PERMISSION OF MACHINE SERVICE INC.

M.S.I. ASSEMBLY No. DRIVESHAFT LAYOUT	
TITLE	—
CUSTOMER	—
CUSTOMER PART No.	—
REFERENCE	—

1000 ASHWAUBENON ST., P.O. BOX 10285, GREEN BAY, WI 54307-0285	
SCALE	3/16"=1"
DATE	06/28/23
SIZE	FILE
A	IND-960
DRAWING NO.	DRIVEN BY
DRIVESHAFT LAYOUT	SPM
REV.	—